

AN EXCHANGE FOR  
G4G12  
Atlanta, March 2016

**PAUL SWINFORD, A TRIBUTE**  
By Jeremiah Farrell

Paul Swinford (1/29/1931-4/26/2000), a Cincinnati magician, entertained at many G4Gs.



A protégé of Stuart Judah he was best known for his two books *Faro Fantasies* (1968) and *More Faro Fantasies* 1971. He also was the Parade editor for the *Linking Ring* (1974-78) and was a major contributor to the *Pallbearers' Review*. His invention of the Cyber Deck in 1983 included an 8-page introduction on the binary system by his friend Martin Gardner. He claimed he had read and absorbed everything available of Gardner and in 1999 published a lecture on numberplay and wordplay.

THE WONDROUS WORLD OF  
NUMBERPLAY & WORDPLAY

PAUL SWINFORD

(photo by ROLING)

A Lecture by

Paul Swinford

To my friend  
Jerry, with  
every good wish,  
Paul Swinford,  
3-15-00

To Jerry, with every  
good wish!  
Paul Swinford  
4-10-00

- $1 \times 9 + 2 = 11$
- $12 \times 9 + 3 = 111$
- $123 \times 9 + 4 = 1111$
- $1234 \times 9 + 5 = 11111$
- $12345 \times 9 + 6 = 111111$
- $123456 \times 9 + 7 = 1111111$
- $1234567 \times 9 + 8 = 11111111$
- $12345678 \times 9 + 9 = 111111111$

In the wordplay part we quote Swinford:

**ANAGRAMS** - Webster defines an anagram as "a word or phrase made by transposing the letters of another word or phrase." The word derives from the Greek word "anagrammatismos" which translates as "to transpose letters." Anagrams have been around for a while. They were invented in 260 B.C. by the Greek poet Lycophron.

A book entitled *Anagrammasia* containing about 5,000 anagrams was published in 1925. Expert opinion holds that only two or three copies are known to have survived. It was compiled by a dedicated anagrammatist who signed on as "Amaranth." Little is known about him except that he was a Pittsburgh attorney with the surname of Lovejoy.

Coming up with anagrams derived from personal names is very much in vogue. The famous mathematician Augustus de Morgan was once presented with a list of 800 anagrams on his name as compiled by one of his admirers. The Internet now offers a program through which one can have a list of computer generated anagrams on any word, phrase or name submitted.

If the personal reference will be excused, I will tell you of the outcome when I submitted my name to "Anagram Genius Server." I was particularly interested to explore this since my name has the rare characteristic of having no repeating letters. I submitted my request and very shortly thereafter down-loaded a list of 200 anagrams based on the 12 letters of my name. Unfortunately, most of them were just nonsensical phrases of little value such as: "Fail drowns up" and "Spur lad if now" and so forth. Things improved a little with "Is darn fowl up?" (Is that lazy pet rooster of mine awake yet?) and "No awful drips?" (Did the plumber do a good job?) With a bit of a stretch, we can justify "Fluids or pawn?" by saying that I was attempting to decide if I wanted to drink two or three beers or go hock my watch.

We now exploit the 12 letters of his name for a variety of puzzles. We first note that using each letter exactly twice one can form the six words DRIP, DUAL, INFO, PLOW, SURF and SWAN. Not so remarkable until one notices that each of the six fit on at least three non-isomorphic graphs.

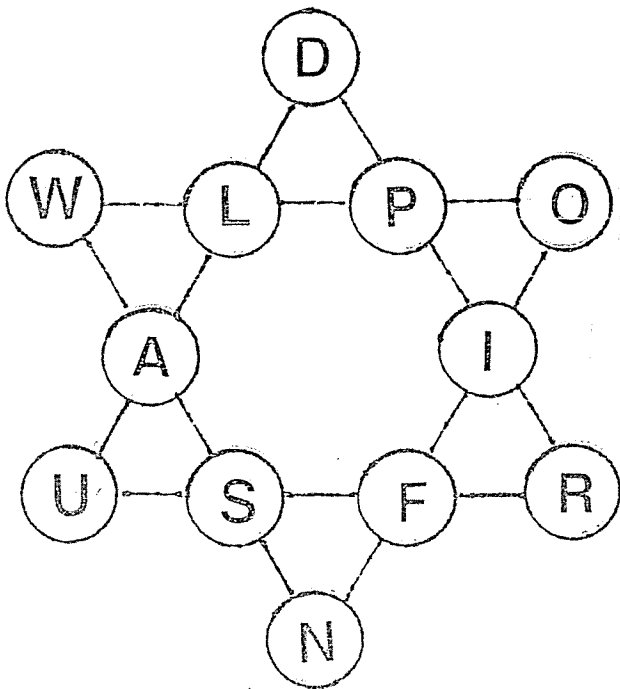
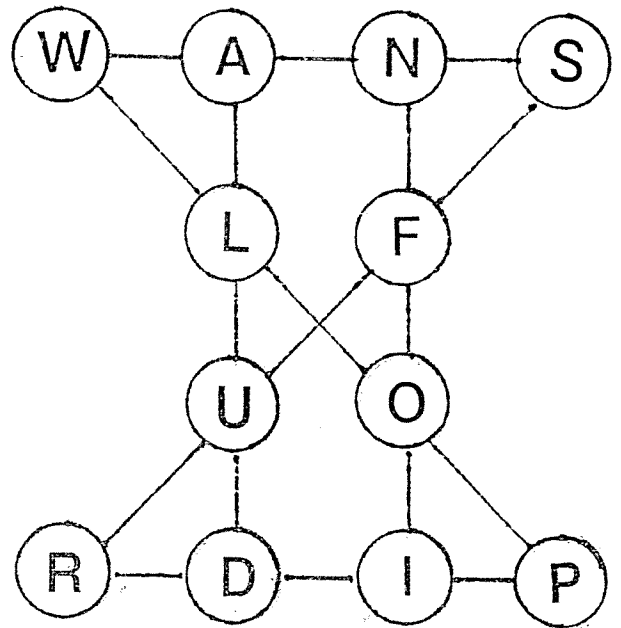
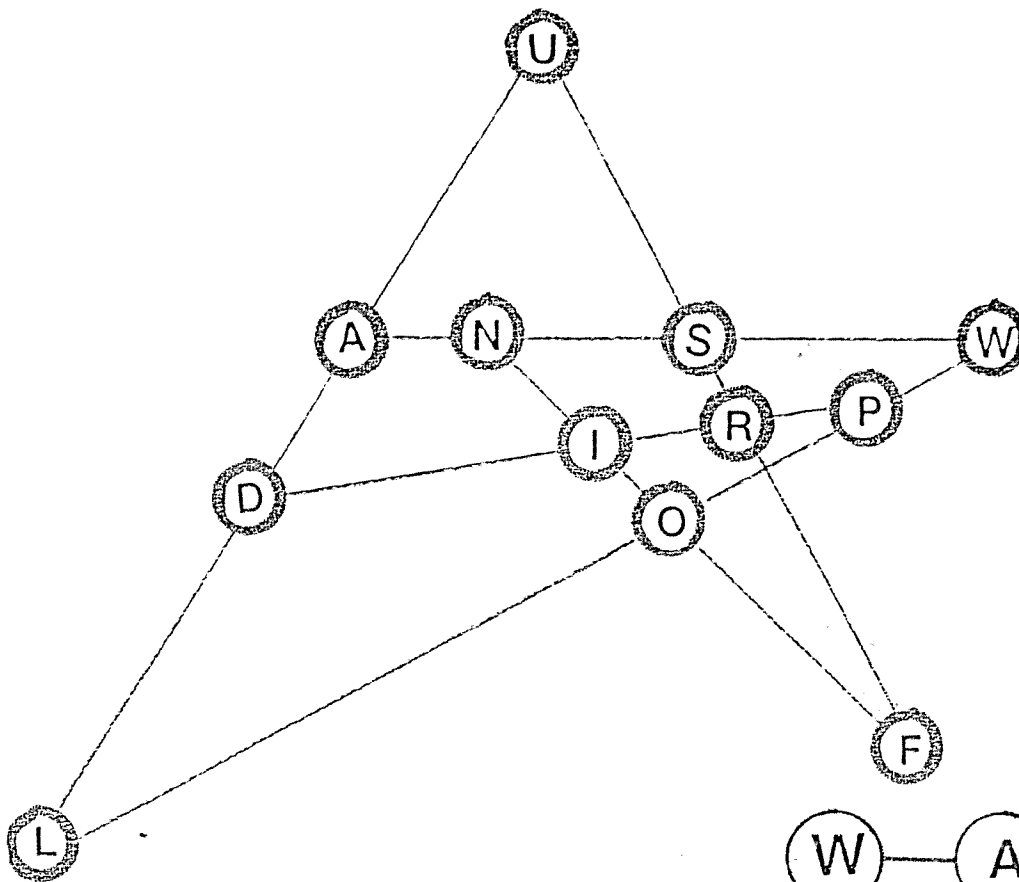

For some numberplay assign the integers 1 to 12 to the letters of PAUL SWINFORD so that every row of four sums to the same constant.

This is an illustration of the concept of isoagonic graphs. That is non-isomorphic graphs that have the same puzzle "struggle".

Use this symmetric diagram to address several puzzles that use the letters of Paul Swinford.

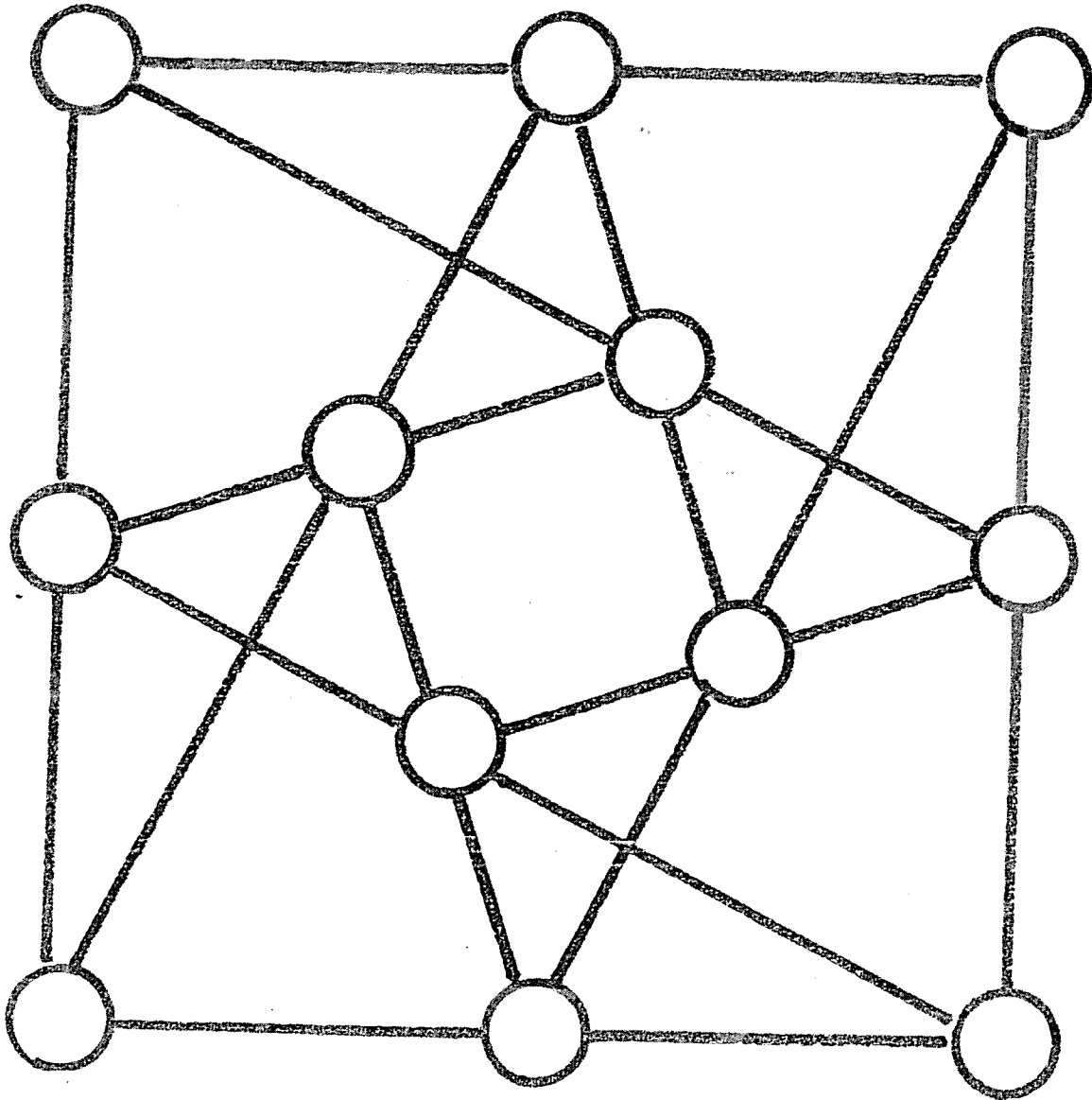

- (1) Place these 12 words on the nodes so that every abutting node has a letter in common.  
 DIP, DOW, FAD, FLU, IFS, LAR (household god), LOP, NOR, PUN,  
 SUR (above, Fr.), WAS, WIN
- (2) Place the 12 letters on the nodes so that each line of three letters anagrams into one of the words AND, FIR, FLU, OFS, OLD, PAL, PUN, RUN, ROW, SAW, SIP, URD (a bean), WIN

Each of these puzzles is a word example of a (12,3) symmetric configuration. See "Configuration Games", p. 93-99 by J. Farrell, M. Gardner, and T. Rodgers in *2005 Tribute to a Mathematician*, AK Peters.

Another puzzle. The following 16 words use the letters of PAUL SWINFORD four times each. Arrange the 16 in the square so that every row and column anagram into our honoree's name.

AND, FAW (a gypsy), FID (a hardwood pin), FLU, FOR, LIP, LON (Chaney), POW, PUD (a fist), RAP, RUN, SAL, SIR, SOD, WIN, WUS (a S. Wales companion).

This square is sometimes called semimagic (the diagonals don't "sum" to the constant) but can be considered as a generalization of the old problem of arranging the 16 court cards so that each row and each column contains one of each suit and one of each value. This is a problem of Jacques Ozanam (1640-1717). In this case the two main diagonals can conform as well. More generally these are instances of Euler orthogonal squares.

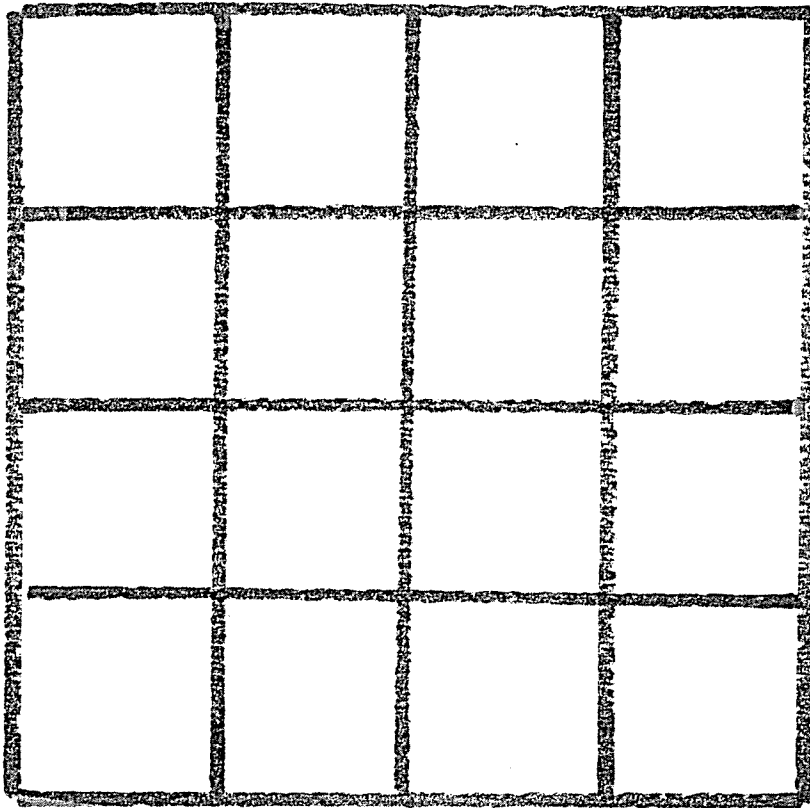

Our final puzzle-game is another (12,3) configuration (there are 229 different such configurations).

The Puzzle. Place the following 12 words on the diagram so that every line of three on the diagram, every diamond of three and every shape of three have a common letter.

DIS (a name for Pluto), DUN, FAN, FLU, FOR, LAW, LOP, RAD (radiation unit), RIP, SOW, SUP, WIN

The Game. Two players alternately place a token on a node and first to obtain three in a row, diamond or shape, wins. We know that such symmetric configurations exist for (9,3), (12,3) and (15,3) similar diagrams. We conjecture that there are infinitely such types.

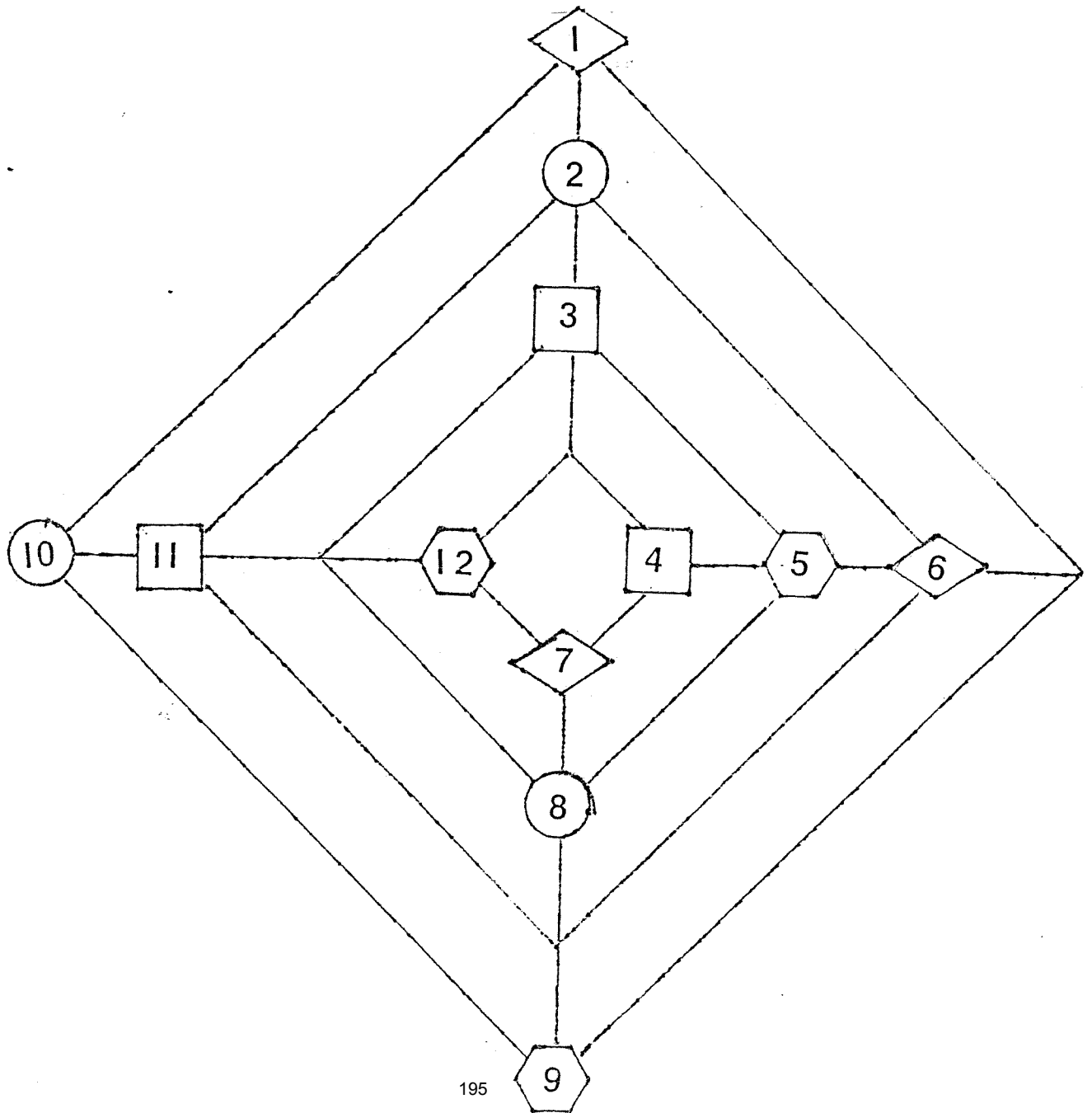

Third (12,3). In 1 to 12 order place these words:

FOR, LOP, SOW, DIS, WIN, RIP, RAD, LAW, FAN, FLU, SUP, DUN

On all of the three symmetric (12,3)s a tic-tac-toe type game may be played and First player can always win from any starting position. The key is to carefully choose a move for which Second must block and waste a turn.

